

VERATM

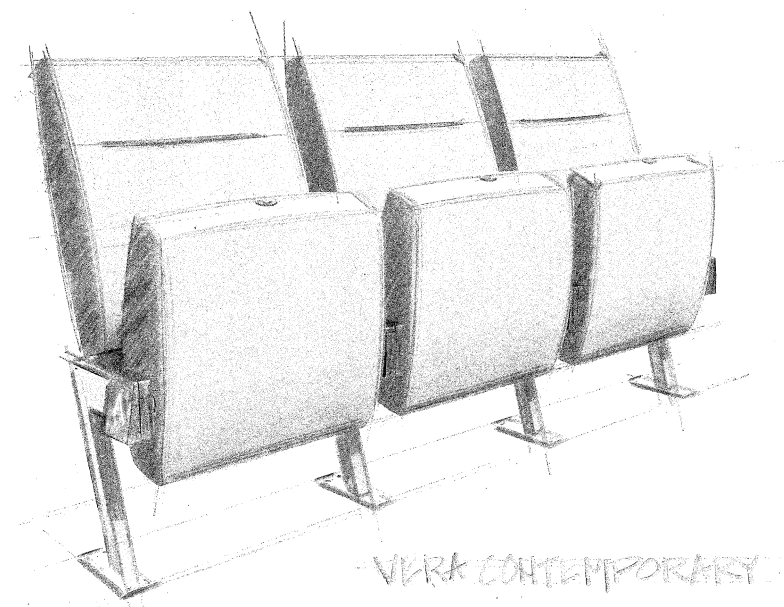

VERA CONTEMPORARY

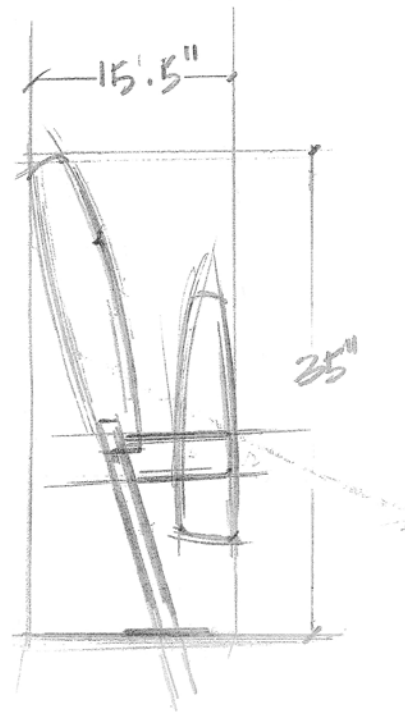

INTELLIGENT DESIGN

The VERA may be the smartest auditorium chair you will see in a long time. Its sleek nonintrusive style incorporates both classic and contemporary influences compatible with any environment. The form and pattern of the chair is deliberately biomorphic. Like the human anatomy, the body of the chair has no straight lines, bringing both visual and tactile harmony between chair and its user. The VERA's ergo-web foundation and surround foam technology conform to the human anatomy in a way that blurs the line on where your body ends and the chair begins. And on the efficiency side, the VERA's accordion design and tight envelope achieves a seat capacity that is 20% greater than conventional pews.

STREAMLINING

From Apple's "Air" products to Boeing's 787 dreamliner, many of the iconic products we esteem today share a common core appeal. In almost every case, the excess bulk found in out of date design has given way to the virtues of space efficiency and physical streamlining. Today's engineering trend towards minimalism inspires product innovation with a clean, uncluttered, unadorned look and feel. The VERA achieves this with features that include our exclusive open-end design and an armless innovation that maximizes visual streamlining and personal space.

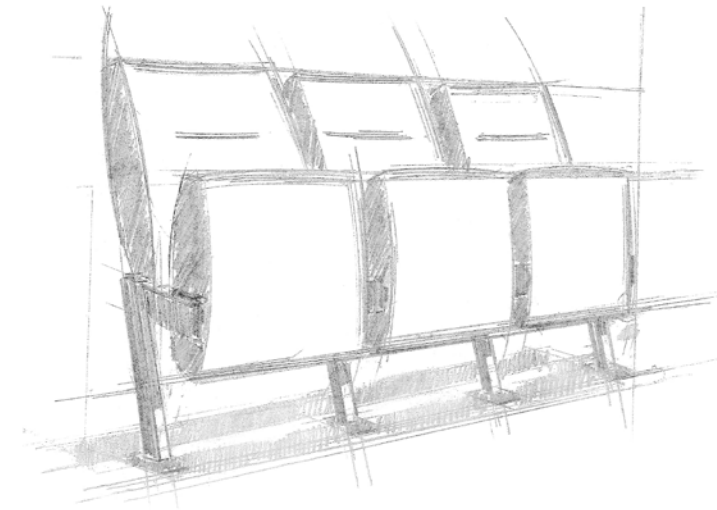

ADDITION BY SUBTRACTION

Several years ago SERIES introduced an equation that added value to the conventional auditorium chair by subtracting arm dividers. At first blush this sounded weird. The market raised its eyebrow and competitors jeered. Yet, to the surprise and quandary of nay-sayers, this "no arm" option quickly grew to represent 97% of our worship market. The added paybacks to the end user, translate to a seat that... (1) is less restrictive for larger people, (2) provides more room at the hips and elbows for all, (3) creates more personal privacy, (4) lowers initial cost, (5) presents a cleaner, uncluttered visual (6) reduces ongoing maintenance, (7) creates a greater sense of community, and (8) ultimately increases seat capacity...Just what you might expect from thoughtful innovation.

GRACE, PACE & SPACE

As a fitting punctuation mark to the VERA statement, we offer a revival to the classic maxim known as "grace, pace and space". The Vera's Graceful lines and streamlined profile keep Pace with today's engineering movement towards a world where less means more, and allows our clients to be better stewards of the valuable entity we know as Space.

ARMLESS DESIGN



Armless Benefits

- Lowers initial cost
- Creates more personal privacy
- Reduces ongoing maintenance
- Is less restrictive to larger people
- Ultimately may increase seat capacity
- Provides more room at the hips and elbows for all

VERA

ARMLESS

Today's engineering trend towards minimalism inspires product innovation with a clean, uncluttered, unadorned look and feel. The VERA features our exclusive open-end design and an armless innovation that maximizes visual streamlining and personal space.



Vera 35 BC SC
Shown with Back Cover, Seat Cover, armless, panel G and floor supports.



VERA

INTERMEDIATE ARMLESS

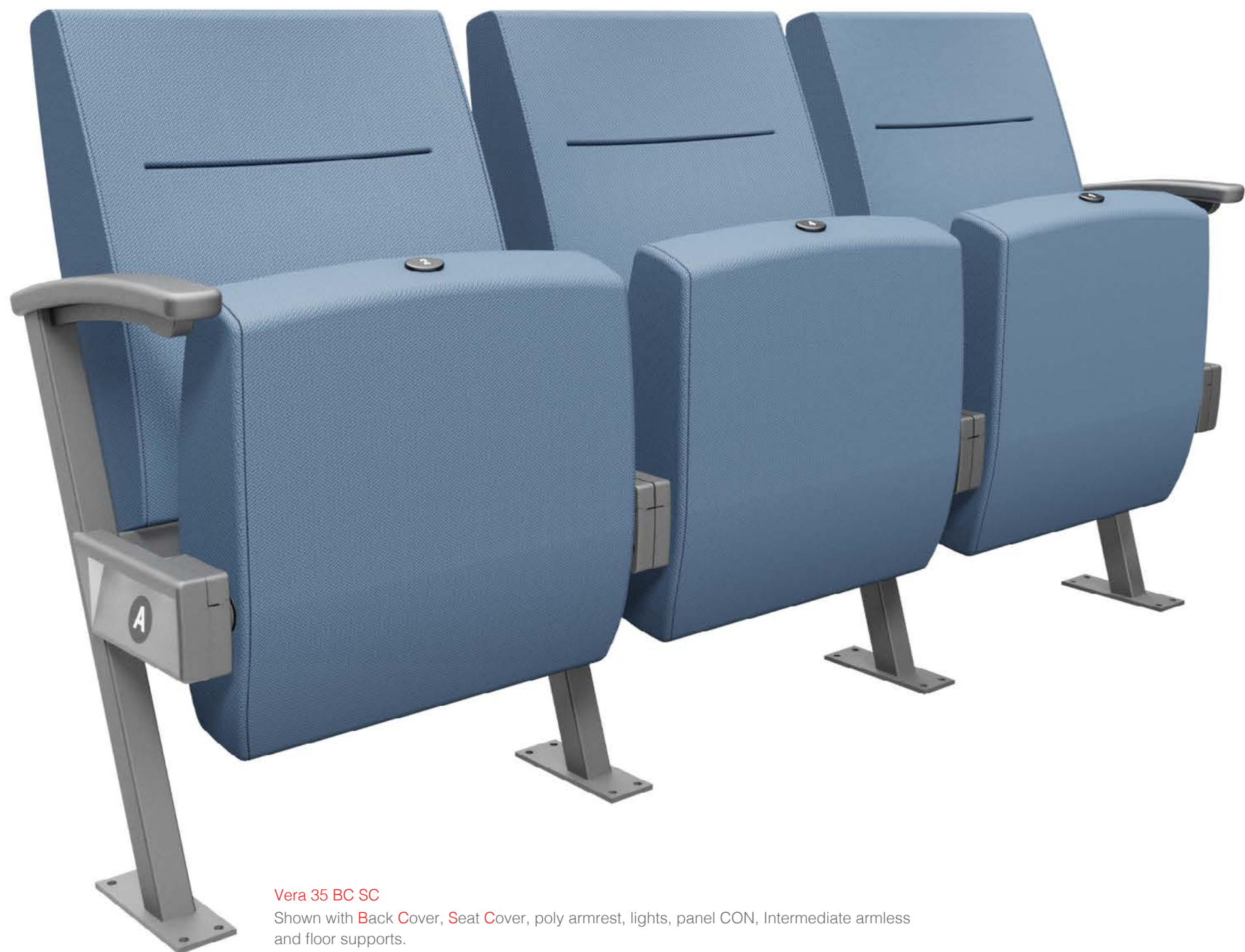

Vera 35 BC SC
Shown with Back Cover, Seat Cover, poly armrest, lights, panel CON, Intermediate armless
and floor supports.



VERA

ARMREST

In exceptional cases when there is a preference to retain the arm dividers, Series offers a crown shaped design that compliments the sleek contours in the chair seat and back. Arms are available in wood or molded poly material.



Vera 35 BC SC
Shown with Back Cover, Seat Cover, poly armrest, lights, panel CON and floor supports.

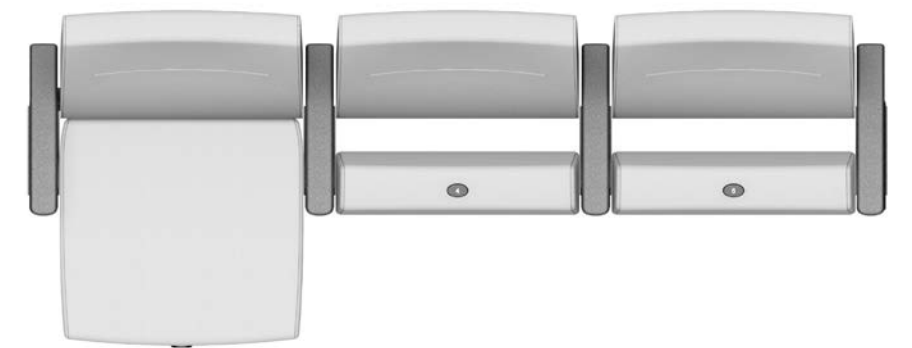

SERIES partnered with the Watermark design team to maximize the sense of a connected experience that is often sacrificed in larger venue spaces. Great care was taken with the seating arrangement to achieve, not only excellent sight lines to the stage, but to other worshipers in the auditorium, for a greater sense of community. Five different fabric colors were employed to visually simulate capacity-attendance when the auditorium seating is only partially occupied, making the room somewhat scalable for smaller events.



THINGS YOU CARE ABOUT

FEATURES & BENEFITS

True **INNOVATION** is much more than the introduction of something new. If it does not meet a need or provide a benefit not being provided by others, it is not innovation. The following is a list of features that are much more than something new. All provide benefits and paybacks like no other auditorium seat product you will find.



ACCORDION SYSTEM

- Rows can be adjusted to any row length on site.
- Single back and seat widths for visual continuity.
- Guarantees perfect alignment of the row ends at the aisle.
- Seats and backs are totally interchangeable.
- Single size components for attic stock.



SURROUND FOAM™

- Foam fully surrounds inner seat and back structure to prevent fabric marks.
- The Ergo-flex seat webbing allows even weight distribution, reduces pressure points, and enhances blood flow achieving optimal healthy comfort.
- Surface to surface airflow in both the seat and back minimizes heat and moisture build up in the foam, prolonging foam life and integrity.



SEAT & BACK DROP-IN ASSEMBLY

- Allows replacement of the seat component in 30 seconds.
- Allows replacement of the back component in 60 seconds.

FLEXIBILITY

Complete Range of Supports

- Floor supports: Flat floor and slopes up to 9°.
- Air floor Supports: Flat floors and slopes up to 9°.
- Riser Supports: Ranging from 6" riser to any required height.
- Pedestal: Flat floor and slopes up to 9°.
- Air pedestal: Flat floor and slopes up to 9°.
- Out-In removable system: 1 chair.
- Back pitch options: 19°, 17°, 14°



SEAT & BACK TUBULAR STEEL STRUCTURE

- Exceeds the most demanding durability tests.
- With heavy use over time, the seat and back components will maintain comfort, alignment and appearance.
- Structure won't be affected by high or low humidity & temperature.



FULLY ENCLOSED AUTOMATIC GRAVITY SEAT LIFT-UP SYSTEM

- Extremely quiet seat lift system.
- The system does not require any lubricants or maintenance.
- Fully enclosed pivot and seat stops that will not permit finger or clothing entrapments.



REMOVABLE SEAT & BACK COVERS

- Allows replacement of the zippered seat cover in 2 minutes.
- Allows the replacement of the back cover in 8 minutes.

OPTIONS TO MEET YOUR NEEDS

Complete Range of Sizes

- Accordion system chair widths: Any dimension between 19 5/8" (498mm) to 24 1/4" (623mm)
- Fixed system chair widths: 20" (508mm), 21" (534mm), 22" (558mm), 23" (584mm)
- Back heights: 35" (890mm), 40" (1016mm), 42" (1066mm), 44" (1118mm)
- Minimum Radius: 23' (7 meters)

SPACE EFFICIENT

TOP VIEW

The VERA takes a quantum leap ahead of the other contenders in space efficiency. The minimal seat envelope provides unmatched generosity in the access and egress space between the rows. This adds to personal comfort and impacts the potential for longer rows and additional seats without violating codes that might restrict the use of competing products.

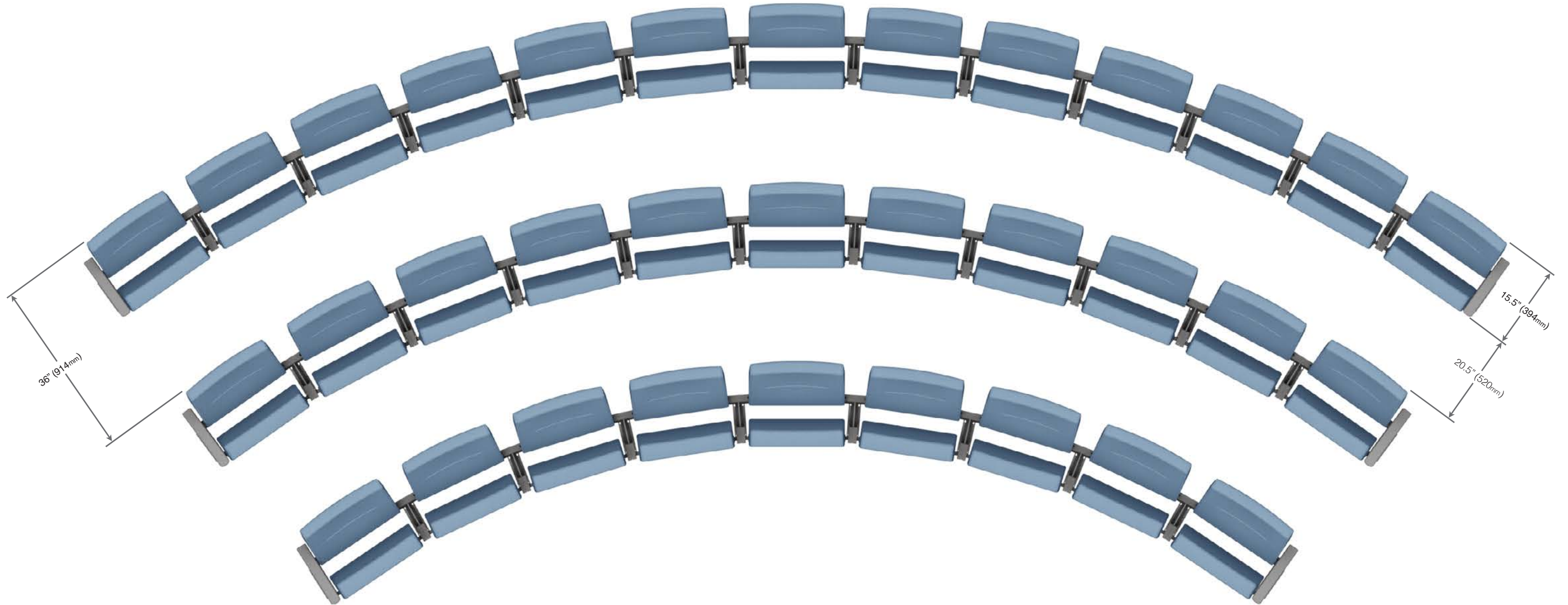

SUPPORT OPTIONS

FLOOR SUPPORT

Floor supports for flat floor and sloped floors up to 9° and a back pitch of 19°, 17°, 14° are standard. Custom pedestal supports are available.



RISER SUPPORT

Riser supports for riser heights from 6" to 24" and a back pitch of 19°, 17°, or 14° are standard. Custom pedestal supports are available.

AIR FLOOR SUPPORT

Air floor supports for flat floor and sloped floors up to 9° and a back pitch of 19°, 17°, 14° are standard. Custom pedestal supports are available.



AIR PEDESTAL SUPPORT

Pedestals and air pedestals supports available for flat floor and sloped floors up to 9° and back pitch of 19°, 17°, 14° are standard. Custom pedestal supports are available.

BACK OPTIONS

BACK HEIGHTS

The VERA is available in higher back options where safety and modesty are considerations. The design maximizes appearance and comfort while retaining our streamlined trademark. The tallest option of 44" maintains a remarkably slim 15 5/16" envelope at a 14° back pitch.



CHAIR WIDTH OPTIONS

ACCORDION SYSTEM

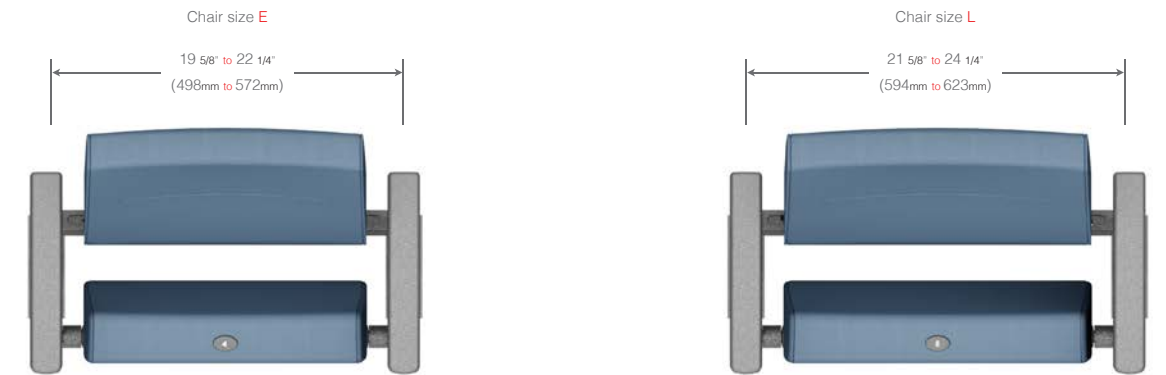

BACK PITCHES

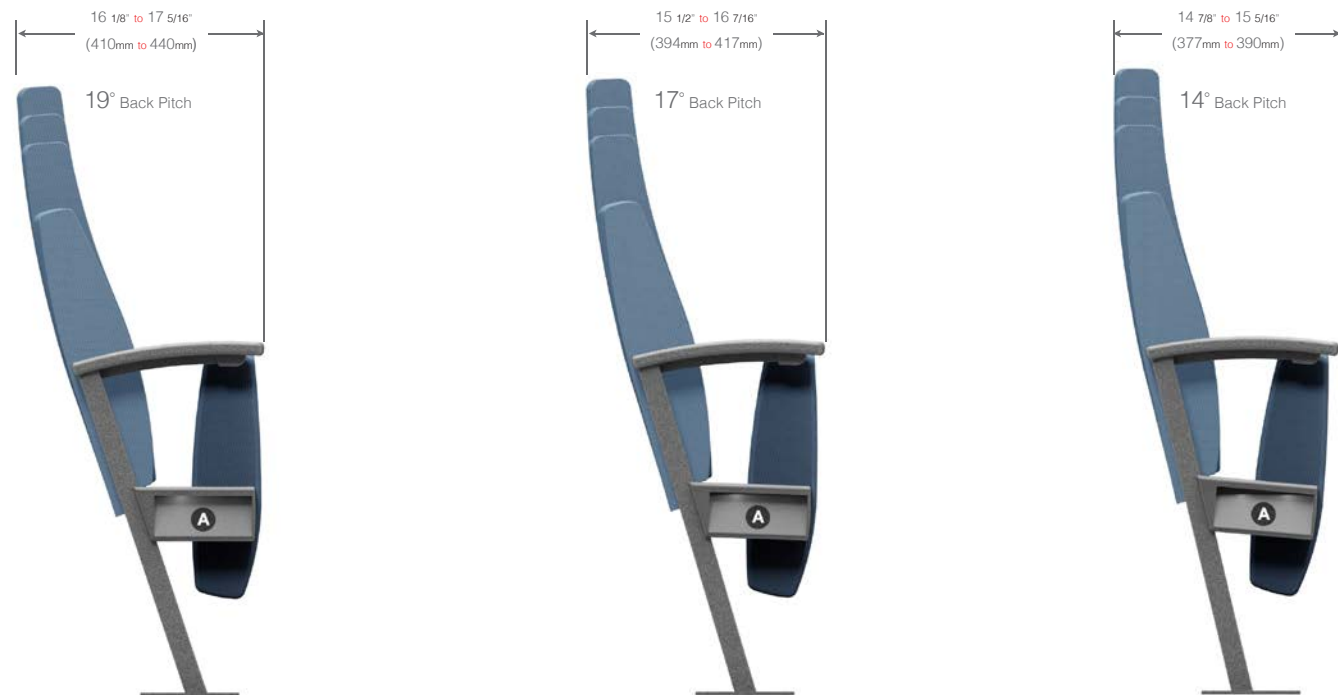

FIXED SYSTEM

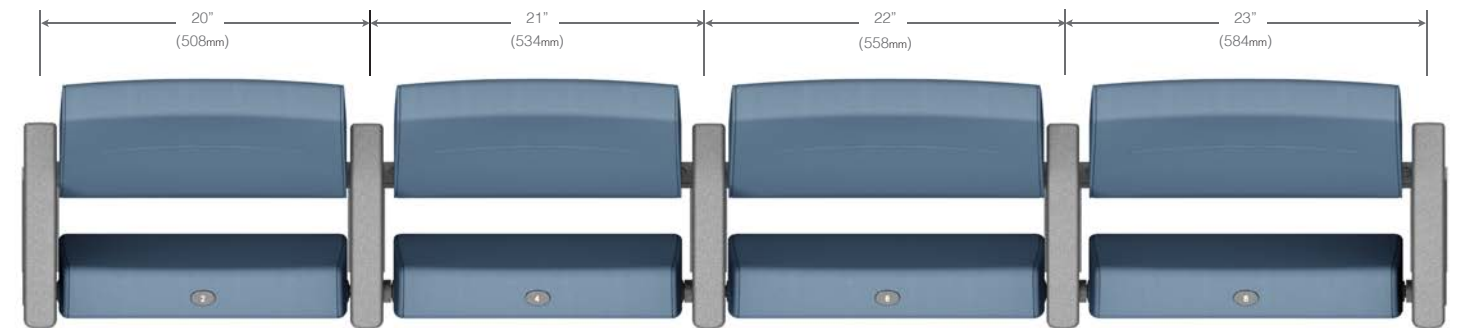

UPHOLSTERY OPTIONS

BACK STITCHING

Single Pleat: Recommended to help hold the upholstery in place over time.



Horizontal Seams: Recommended to increasing the performance of leather over time.



No horizontal seams/pleats : Recommended with Marine Grade Vinyl for outdoor use.



All back stitching types allow for easy upholstery replacement (replaceable in less than 6 minutes).
Seat Covers are easily replaced with zippered removable seat covers (replaceable in less than 2 minutes).

POLY BACK OPTION

Polyurethane/Ballistic Nylon Outer back option: Recommended to be paired with fabric selections that have lower abrasion resistance.

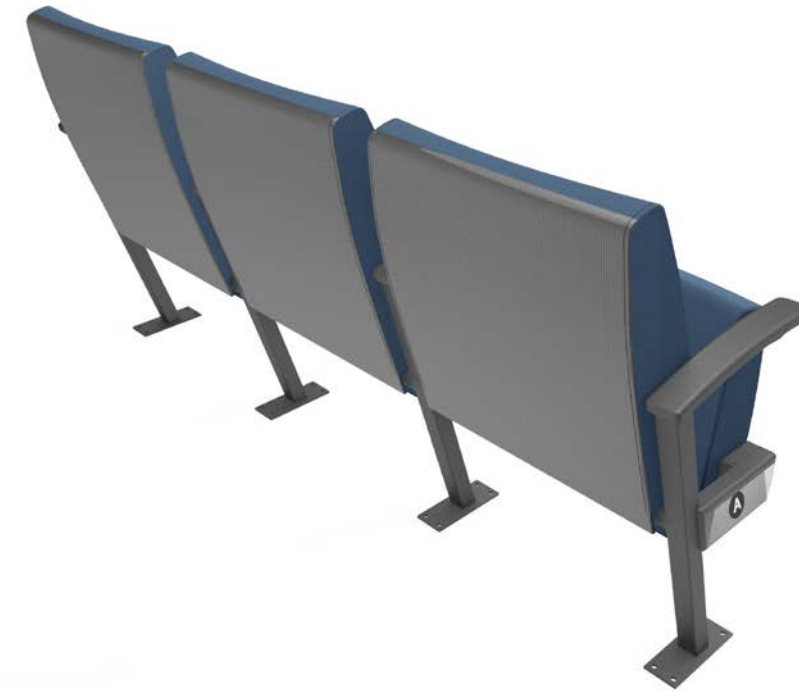

POLY SEAT OPTION

Polyurethane/Ballistic Nylon Under Seat Option : Recommended to be paired with fabric selections that have lower abrasion resistance.



BOOK HOLDER

SINGLE BOOK UNIT

SERIES keeps the clutter away from your field of vision by designing accessories such as book holders and card and pencil holders that do not have to be attached to the rear of the backs. The book racks are secured to the steel frame down low and out of the way while the card and pencil holders are secured discreetly below the side seat brackets.

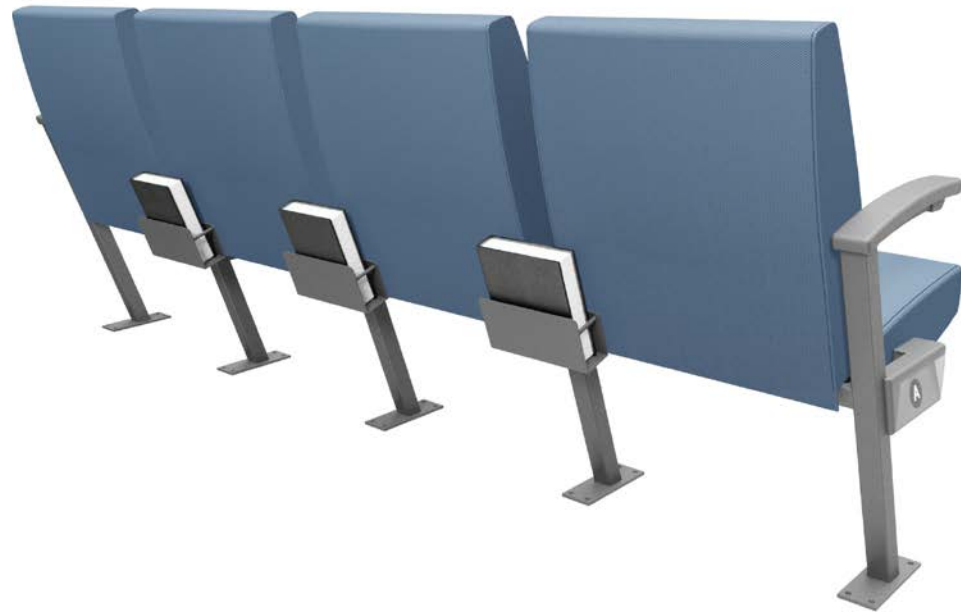

Single book holder interior dimensions: Width 7 1/2" (191mm) Depth 2 1/2" (64mm) Height 3 7/8" (98mm).
PA32321

DOUBLE BOOK UNIT

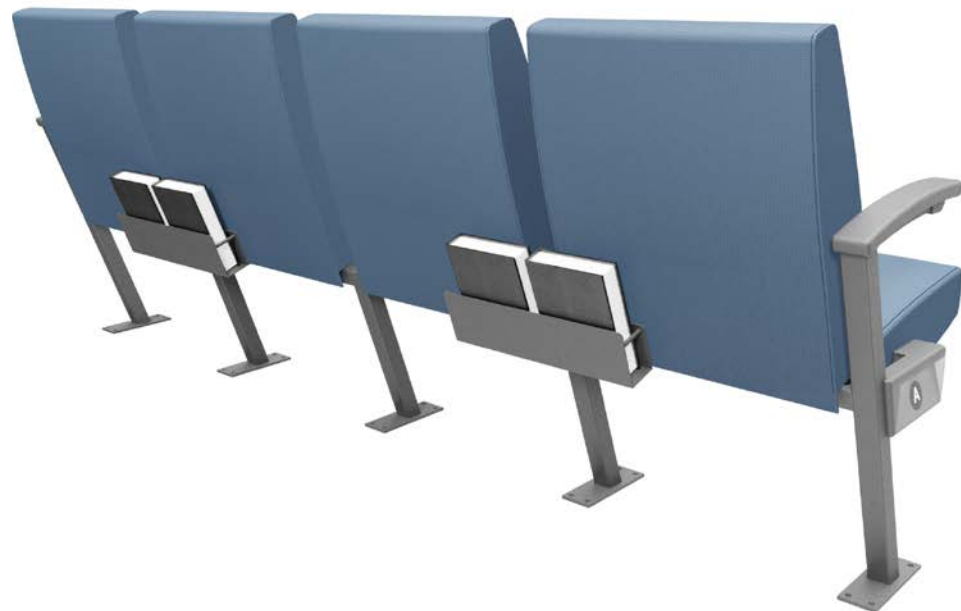

Double book holder interior dimensions: Width 14 7/16" (367mm) Depth 2 1/2" (64mm) Height 3 7/8" (98mm).
PA32284

CARD HOLDER

CARD UNIT



Side mount polyurethane card pencil holder.
PA31761

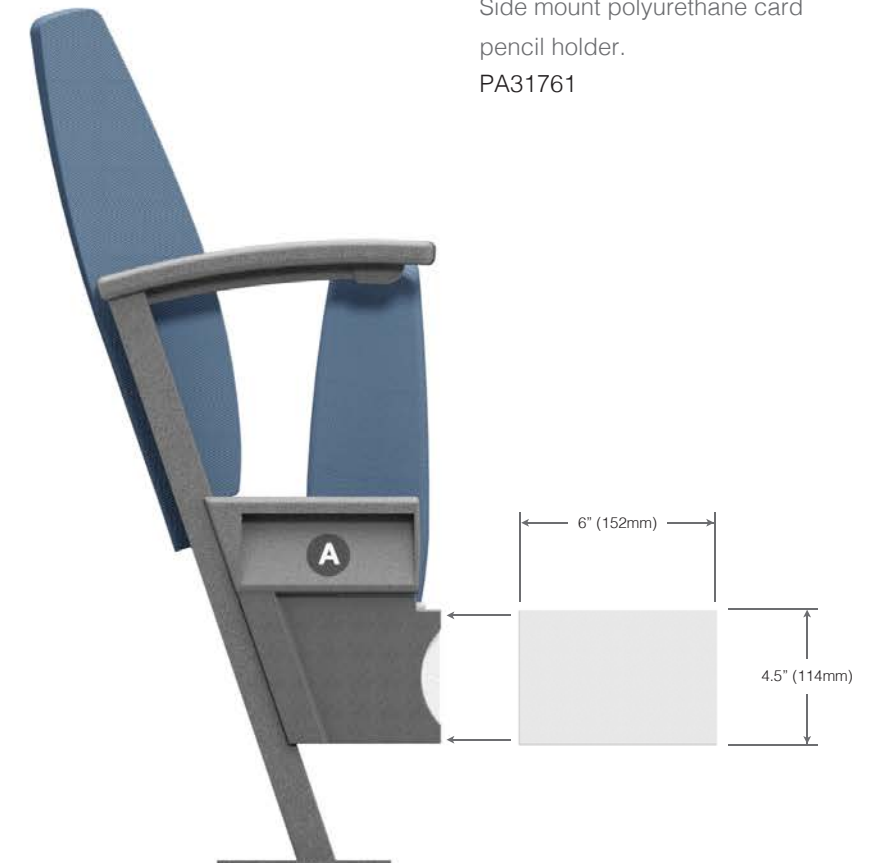

SIGNAGE

SEAT IDENTIFICATION

Prominent, well thought out signage placement is built into this seating system.



Seat Identification
Polymer number plate placed with concealed fasteners. Font white Helvetica numbers
Plate dimensions: 1" x 1 1/2" (26mm x 42mm)
PA9712

ROW IDENTIFICATION

Angled polymer letter plate for easy viewing, placed with concealed fasteners.
Font white Helvetica lettering.



Panel **CON**
PA31434 right panel and PA31435 left panel.
Letter plate dimension: 1 3/4" (45mm) diameter.
MP8413



Panel **G**
PA30146 right plate and PA30147 left plate.
Letter plate dimensions: 4" x 3 1/4" (100mm x 85mm)

AISLE LIGHT

IDENTIFICATION



Warm White 3 LEDs and 12 VDC,
PA13398 right light, and PA13397 left light.

ADA

LIFT-UP ARM

ADA compliance is required by code for many new and renovated public seating facilities. The Vera line of seating provides seamless ADA compliant seating options.



The ergonomic design of the ADA compliant seating provides both comfort and ease of use to patrons. The polyurethane cushion has a soft texture and the seating design is very quiet, allowing egress to occur without interruption.

CUPHOLDER

DRINKS

Cupholder Options

- 1 Armrest Mount PA31921
- 2 High Rear Support Mount PA11517
- 3 Low Rear Support Mount PA11517
- 4 Front Floor Support Mount PA13391
- 5 Front Riser Support Mount PA13391

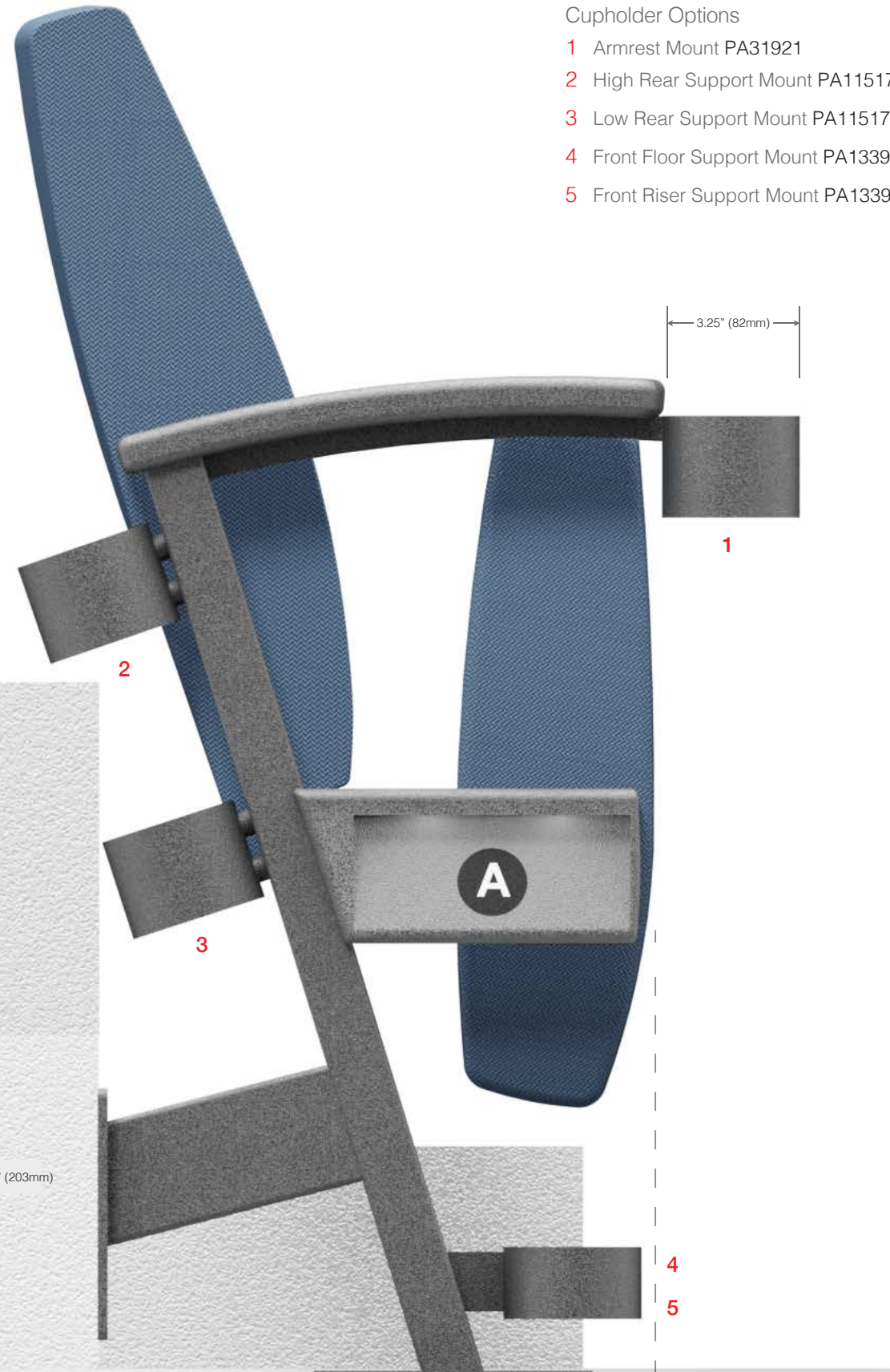

CUPHOLDER

COMMUNION

Communion Cupholder Options

- 1 Armless Support Mount PA12598
- 2 Armrest Support Mount PA12598



CUT VIEW

SPECIFICATIONS

Back Structure

Structural tubular steel pipe, wall thickness 0.079" (2 mm).

Surround Foam™

Contour-molded high-density open cell, cold cured foam 4.1/2" (114mm) thickness
Density: 2.8 lb./ft3 (45 Kg/m3)
Custom foam densities and firmness available upon request. The foam fully surrounds the structure to help prevent fabric marks.

Supports Mounts Options

Floor, riser, pedestal, removable
1, 2, 3 seat configurations and removable Out-In pedestal.

Back Drop-In Assembly

Patented drop-in assembly allows the installation or replacement of the back cushion with the use of only two Hex 1/4" screws in less than 1 minute.

Automatic Gravity Seat Lift-up System

Silent gravity lift-up system with encapsulated steel weight and fully enclosed pivot and seat stops.

Open End Panel-Row Identification

Angled polymer letter plate for easy viewing, with concealed fasteners.

Seat Drop-in Assembly

Patented drop-in assembly that allows the installation or replacement of the seat cushion in less than 30 seconds.

Ergonomic Seat Cushion

Flexible mesh that prevents user from bottoming down and prevents foam cushions from building up heat.

Supports Base Plate

Steel plates 1/4" (6mm).

Back Cover

Standard SERIES Seating fabric or COM covers.

Fire Barrier

Optional fire protection barrier.

Armrest Pad

Optional Polymer pad.

Ergonomic Back Cushion

Compound curved back cushion with lumbar support.

Metal Exposed Components Finish

Black color oven backed polyester electrostatic powder-coated paint. Custom color available. Hot dip galvanized protection available.

Zippered Removable Seat Cover

Standard SERIES Seating fabric or COM covers.

Seat Identification

Polymer number plate with concealed fasteners.

Surround Foam™

Contour-molded high-density open cell, cold cured foam 5" (127mm) thickness. Density: 3.4 lb./ft3 (54 Kg/m3) Custom foam densities and firmness available upon request. The foam fully surrounds the structure to help prevent fabric marks.

Seat Structure

Structural tubular steel pipe, wall thickness 0.079" (2 mm).

Accordion System™

Allows installing the chairs at any chair width dimension that does not exceed 2 1/2" (63.5mm) from its original chair width dimension. Chairs can be installed in radius, reverse radius or straight row configurations.

- Metal exposed components are electrostatic powder-coat painted, oven baked to a thickness of 3 mils
- Chair Assembly only requires the use of a 7/16" wrench to tighten two 1/4" bolts
- All Anchors and hardware are zinc plated

SPECIFICATION

DIMENSIONS

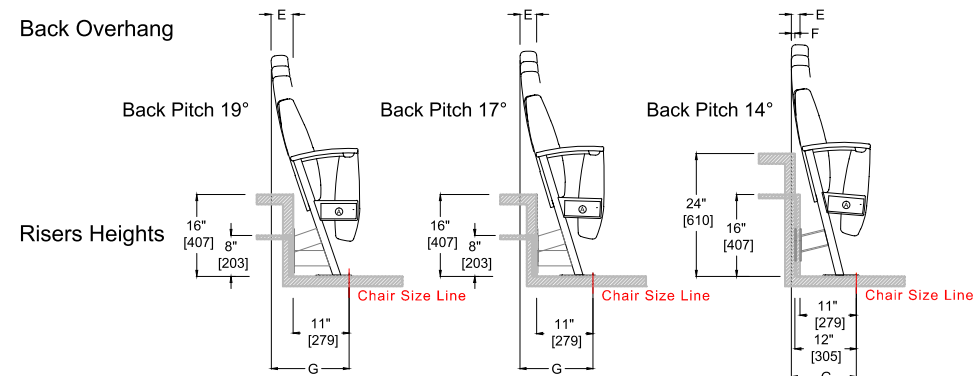
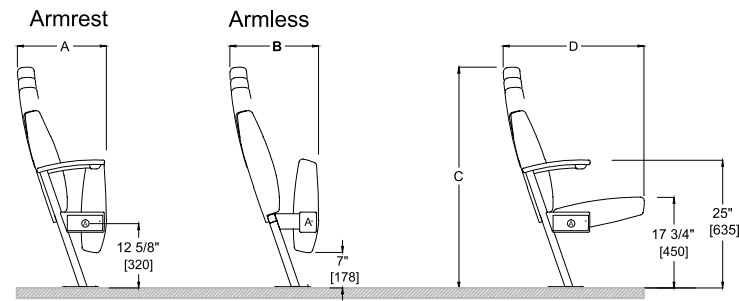

	Back Pitch Angle	Back Height			
		35°- 890mm	40°-1016mm	42°-1067mm	44°-1118mm
Envelope Armrest Chair	A 19°	16 1/8" 410 mm	17" 432 mm	17 3/16" 437 mm	17 5/16" 440 mm
	17°	15 1/2" 394 mm	16 1/4" 413 mm	16 3/8" 416 mm	16 7/16" 417 mm
	14°	14 7/8" 377 mm	15 5/16" 390 mm	15 5/16" 390 mm	15 5/16" 390 mm
Envelope Armless Chair	B 19°	16 1/8" 410 mm	17" 432 mm	17 3/16" 437 mm	17 5/16" 440 mm
	17°	15 1/2" 394 mm	16 1/4" 413 mm	16 3/8" 416 mm	16 7/16" 417 mm
	14°	14 7/8" 377 mm	15 5/16" 390 mm	15 5/16" 390 mm	15 5/16" 390 mm
Back Height	C 19°	34 5/8" 879 mm	39 3/16" 995 mm	41 3/16" 1045 mm	43 1/8" 1095 mm
	17°	35 7/16" 900 mm	40" 1017 mm	42" 1067 mm	44" 1118 mm
	14°	36 5/8" 930 mm	41 1/4" 1048 mm	43 1/4" 1099 mm	45 5/16" 1150 mm
Chair Depth Seat in Down Position	D 19°	26 5/16" 669 mm	27 3/16" 691 mm	27 3/8" 696 mm	27 1/2" 699 mm
	17°	25 13/16" 655 mm	26 1/2" 674 mm	26 5/8" 677 mm	26 11/16" 678 mm
	14°	24 13/16" 631 mm	25 5/16" 643 mm	25 5/16" 643 mm	25 5/16" 643 mm
Back Overhang Up to 16" Riser Height Face	E 19°	3 1/16" 78 mm	3 15/16" 101 mm	4 1/8" 105 mm	4 1/4" 109 mm
	17°	2 3/8" 60 mm	3 1/16" 78 mm	3 3/16" 81 mm	3 1/4" 83 mm
	14°	1 1/4" 32 mm	1 3/4" 44 mm	1 3/4" 44 mm	1 3/4" 44 mm
Back Overhang Up to 24" Riser Height Face	F 14°	1/4" 6 mm	3/4" 18 mm	3/4" 18 mm	3/4" 18 mm
	G 19°	14 1/16" 357 mm	14 15/16" 380 mm	15 1/8" 385 mm	15 1/4" 388 mm
Back Overhang From Chair Size Line	17°	13 3/8" 339 mm	14 1/16" 358 mm	14 3/16" 361 mm	14 1/4" 362 mm
	14°	12 1/4" 311 mm	12 3/4" 323 mm	12 3/4" 323 mm	12 3/4" 323 mm

Armrest Size "E": Any chair width dimension between 19 5/8" to 22 1/2" (498mm to 572mm)

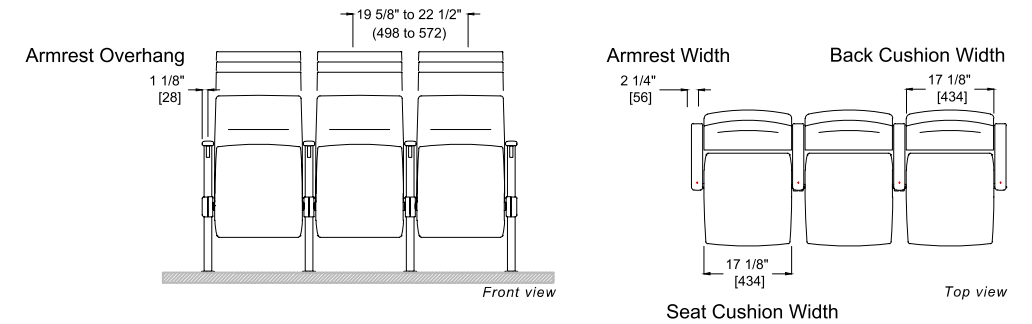

Armrest Size "L": Any chair width dimension between 21 5/8" to 24 1/2" (594mm to 623mm)

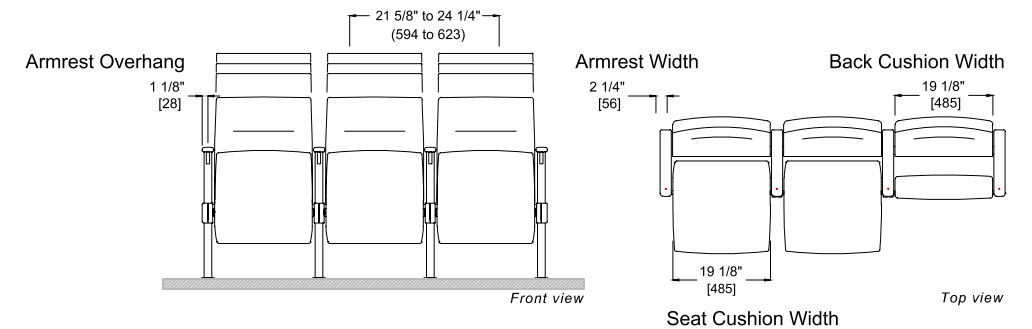

Armless Size "E": Any chair width dimension between 19 5/8" to 22 1/2" (498mm to 572mm)

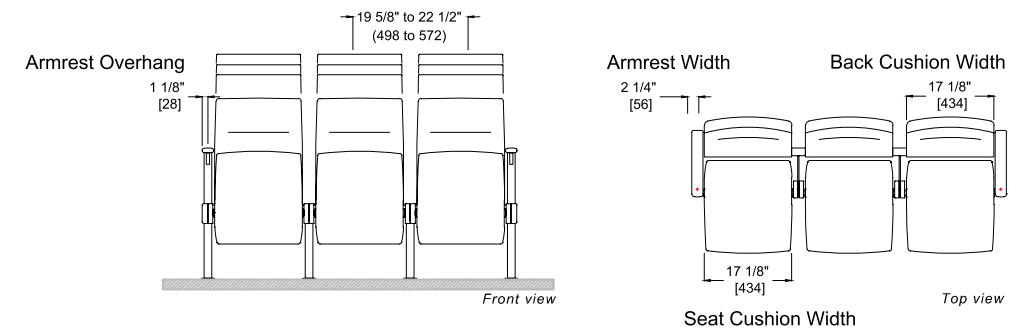

Armless Size "L": Any chair width dimension between 21 5/8" to 24 1/2" (594mm to 623mm)

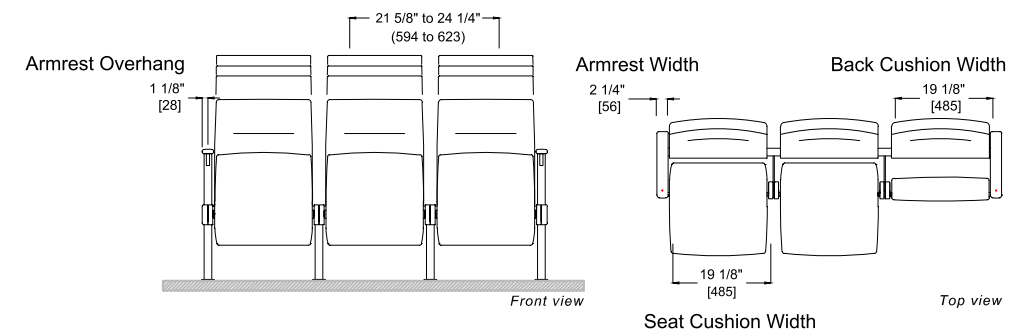





SERIES USA

Corporate Headquarters

20900 NE 30th Avenue

Suite 901

Miami, FL 33180

P 1 - 800 - 729 - 1190 | + 1 - 305 - 932 - 4626

E info@seriesseating.com

SERIESWORSHIPSEATING.COM | SERIESSEATING.COM

SERIES Colombia

Carrera 7A Km. 21

Chía, Cundinamarca 250008

P + 57 - 1 - 518 - 8585

E info@seriesseating.com

SERIESWORSHIPSEATING.COM | SERIESSEATING.COM

SERIES Australia PTY LTD

68 Salamaner Way

Salamaner Bay, NSW 2317

P + 61 - 2 - 9986 - 3878 | + 61 - 412 - 085 - 982 | + 61 - 0412 - 435 - 089

E rxp@hadleyaustralia.com.au | hadley@hadleyaustralia.com.au

HADLEYAUSTRALIA.COM.AU | SERIESSEATING.COM

Member of Australasian Furnishing Research & Development Institute

© 2018 SERIES® Seating

Printed in USA by SERIES® Printing on FSC certified paper

0411181645

